

## Fork-Liftable Caged Cart

This unit is a perfect solution for order picking in warehouses and distribution centres. The unit is designed in a manner that allows it to be lifted easily with a forklift, reducing manual intervention from associates.

### Features:

- Constructed of all steel, with powder coated gray body and powder coated yellow shelves
- Enclosed on three sides
- D-shaped handles in front
- Shelves can be folded and placed at the back
- Maneuvers easily on 6" swivel polyurethane with brakes.

### Benefits:

- All steel construction gives a sturdy structure and allows for extensive use in harsh conditions
- Metal enclosure on three sides provides protection against damage to items
- Ergonomic placement of D-shaped handles allows the unit to be pushed around easily, without much effort
- 6" swivel polyurethane wheels makes the cart mobile
- The ability to lift the cart with a forklift reduces movement wastage and saves time



**EC-3040-71H-SEC**



Founded in 1946

## Fork-Liftable Caged Cart

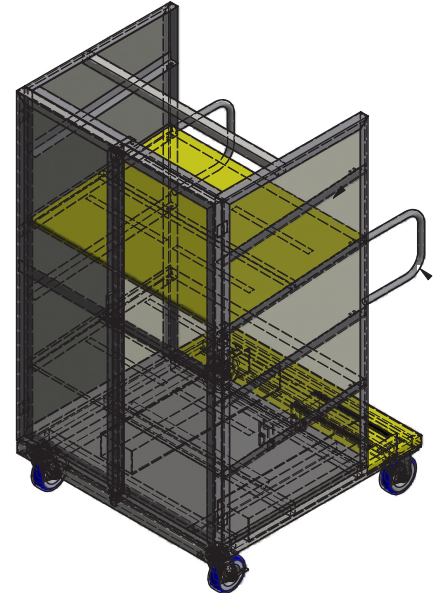
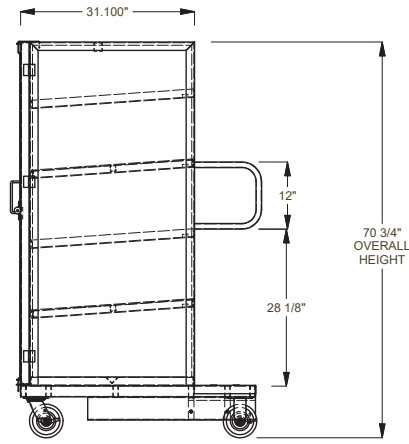
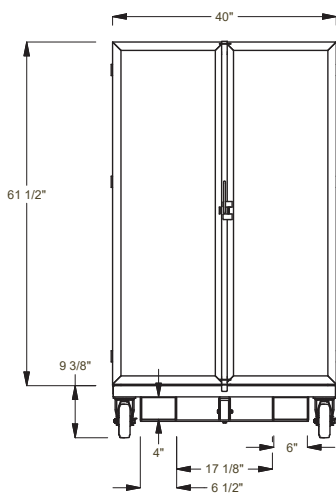
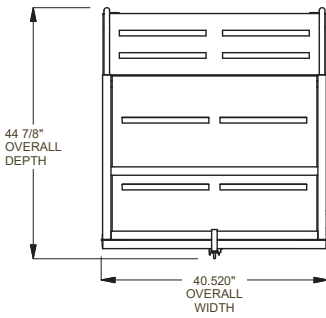

Model Number	Order#	Overall Dimensions						Approx. Ship Wt	
		Width		Length		Height			
		(in)	(mm)	(in)	(mm)	(in)	(mm)	(lb)	(kg)
EC-3040-71H-SEC	1095718	40.52	1029.2	44.875	1139.83	70.75	1797.05	95	43.1



In line with our policy to continually improve our products, Winholt reserves the right to change materials and specifications without notice.