

In-store impulse-generating merchandiser

Multi Deck 60 - 3 level
Premium Eylene



The Fri-Jado Multi Deck Eylene boosts hot food-to-go sales with an irresistible product presentation on eye level. Thanks to the high underframe, the Multi Deck Eylene provides great visual merchandising. It can be used anywhere in the store to stimulate customers to pick up hot grab-and-go products.

Our patented Hot Blanket holding technology controls food safety. Hot air is blown from the front of the shelf and circulates over the shelf surface, after which it is recycled into the unit. Your products are completely surrounded by a blanket of hot air, ensuring an even holding temperature.

Large, transparent side panels provide a 180-degree view on your products. The appealing design provides an outstanding product presentation which is sure to boost impulse sales.

Features MD 60 - 3 Premium Eylene

Top features

- Eye-level presentation - high underframe
- Illuminated canopy with customizable signage
- Customizable price strips on each shelf
- Hot Blanket holding technology - keeps products warm at 65° for at least 4 hours
- Endless possibilities - ideal for chicken (portions), panini, pies, pastries, soups, hot rolls, wraps etc.

Standard characteristics

- Self serve heated Multi Deck display unit
- Curved design
- 60 cm wide - 3 level display
- Total presentation area of 0.78 m²
- Footprint of 0.48 m²
- Solid back
- Angled shelves provide optimum product visibility
- Shatter-resistant clear side glass for optimum safety
- Front bumpers to protect from shopping carts
- Saves up to 20% on energy by air-curtain technology on each shelf
- 98% recyclable (environmentally friendly)
- Plug-and-play

Accessories

- Customer-side temperature indicator
- Shelf leveler



Optimum product visibility



Signage



High underframe

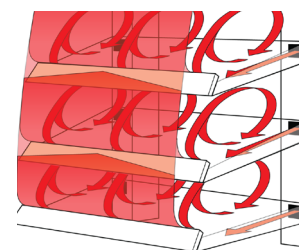

Keeps hot food at 65°C

MD 60-3 Premium Eyeline

1 Power cable, 2 m

Dimensions

Width	600 mm
Depth	800 mm
Height	1800 mm

Technical data

Net weight	155 kg
Gross weight	182 kg
Voltage	1N~ 230 V
Frequency	50/60 Hz
Power	2.4 kW

Specifications and technical data are subject to amendment without notice.

These are basic drawings. For more detailed technical information, please refer to the installation manual at www.frijado.com.

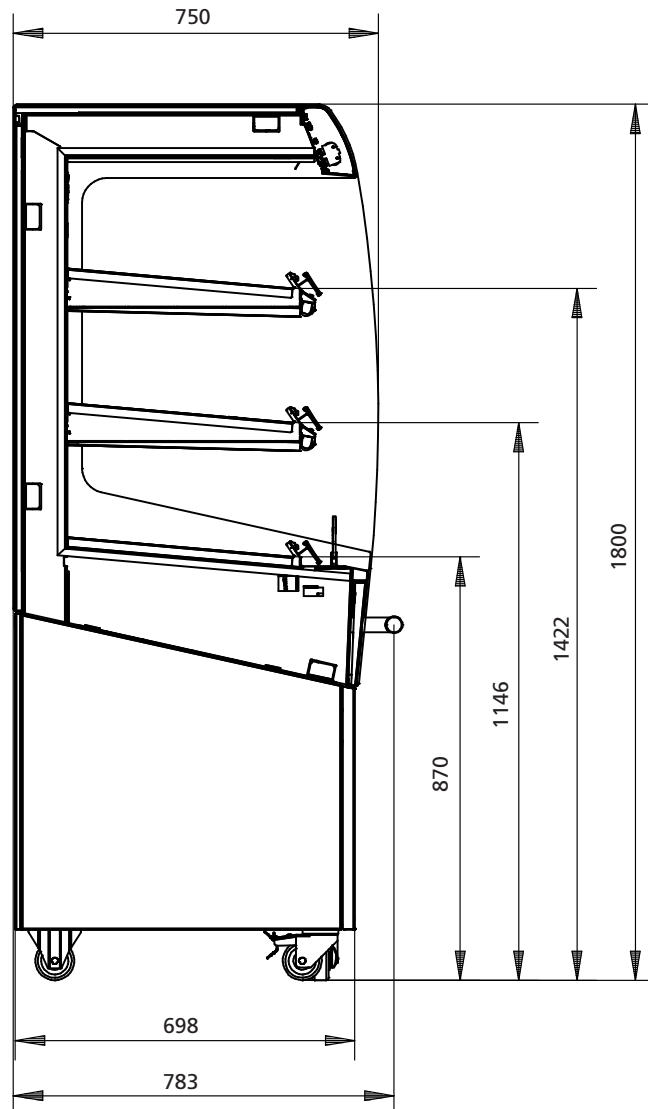
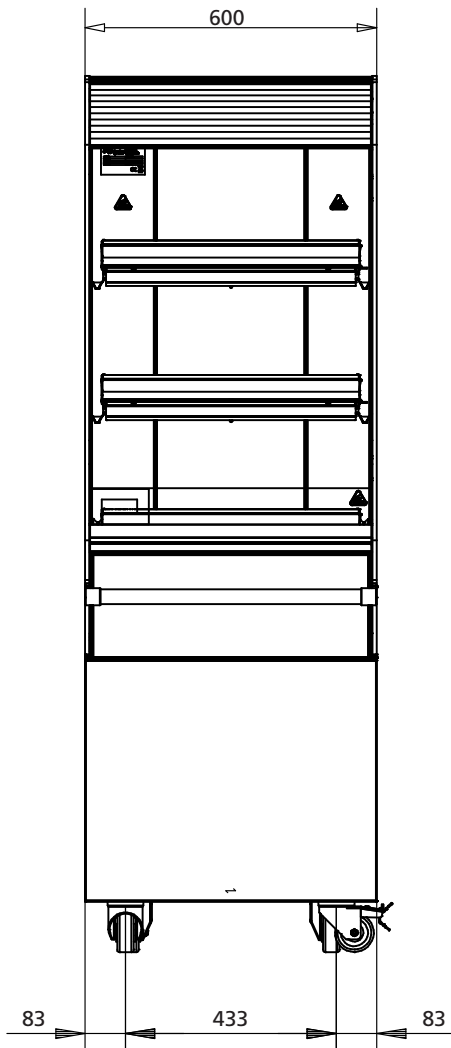
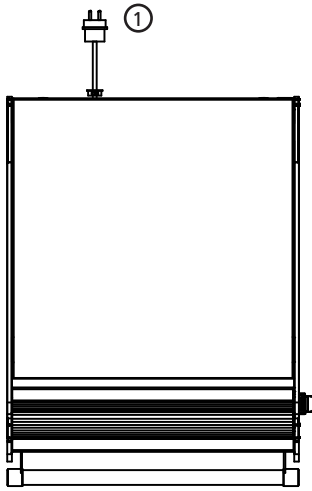

In-store impulse-generating merchandise

Multi Deck 100 - 3 level
Premium Eylene



The Fri-Jado Multi Deck Eylene boosts hot food-to-go sales with an irresistible product presentation on eye level. Thanks to the high underframe, the Multi Deck Eylene provides great visual merchandising. It can be used anywhere in the store to stimulate customers to pick up hot grab-and-go products.

Our patented Hot Blanket holding technology controls food safety. Hot air is blown from the front of the shelf and circulates over the shelf surface, after which it is recycled into the unit. Your products are completely surrounded by a blanket of hot air, ensuring an even holding temperature.

Large, transparent side panels provide a 180-degree view on your products. The appealing design provides an outstanding product presentation which is sure to boost impulse sales.

Features MD 100 - 3 Premium Eylene

Top features

- Eye-level presentation - high underframe
- Illuminated canopy with customizable signage
- Customizable price strips on each shelf
- Hot Blanket holding technology - keeps products warm at 65° for at least 4 hours
- Endless possibilities - ideal for chicken (portions), panini, pies, pastries, soups, hot rolls, wraps etc.

Standard characteristics

- Self serve heated Multi Deck display unit
- Curved design
- 100 cm wide - 3 level display
- Total presentation area of 1.32 m²
- Footprint of 0.8 m²
- Solid back
- Angled shelves provide optimum product visibility
- Shatter-resistant clear side glass for optimum safety
- Front bumpers to protect from shopping carts
- Saves up to 20% on energy by air-curtain technology on each shelf
- 98% recyclable (environmentally friendly)
- Plug-and-play

Accessories

- Customer-side temperature indicator
- Shelf leveler



Optimum product visibility



Signage



High underframe

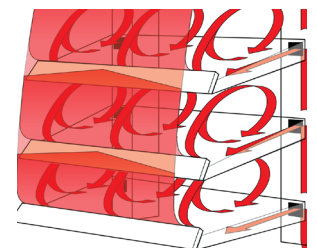

Keeps hot food at 65°C

MD 100-3 Premium Eyeline

1 Power cable, 2 m

Dimensions

Width	1000 mm
Depth	800 mm
Height	1800 mm

Technical data

Net weight	209 kg
Gross weight	235 kg
Voltage	1N~ 230 V
Frequency	50/60 Hz
Power	3 kW

Specifications and technical data are subject to amendment without notice.

These are basic drawings. For more detailed technical information, please refer to the installation manual at www.frijado.com.

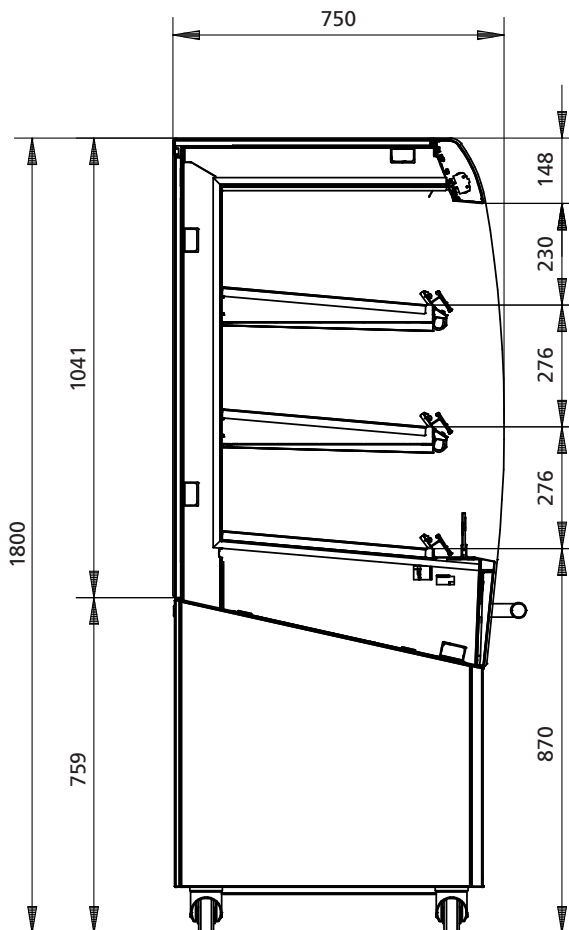
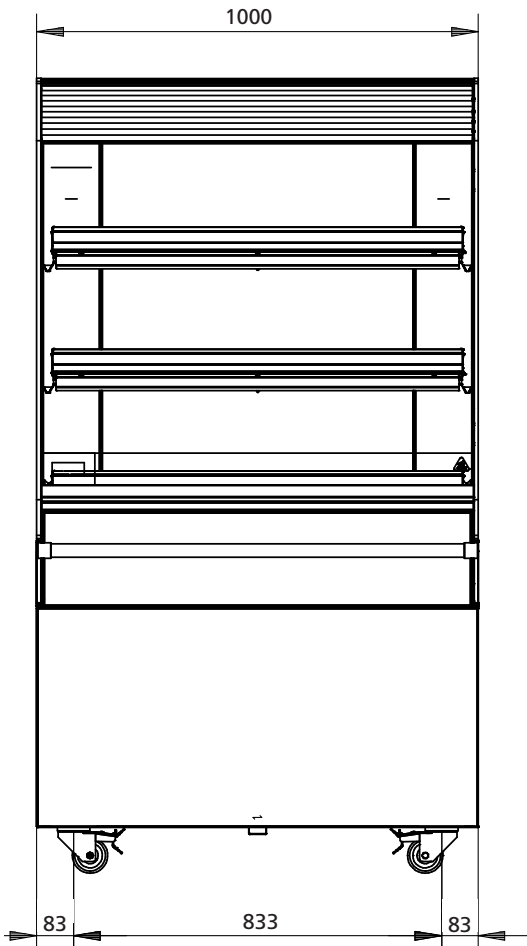
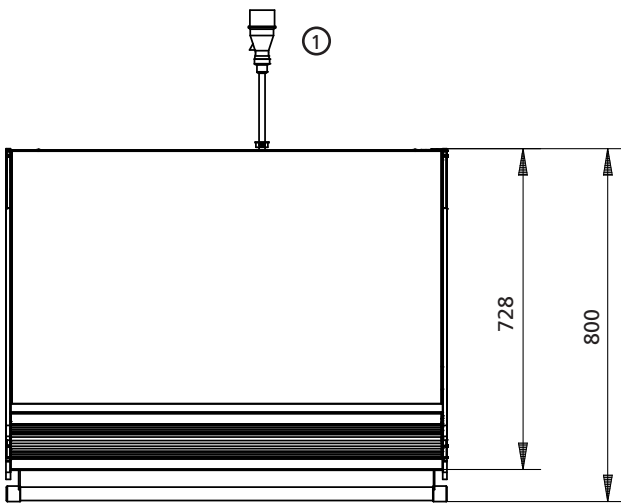

In-store impulse-generating merchandise

Multi Deck 120 - 3 level
Premium Eycline



The Fri-Jado Multi Deck Eyeline boosts hot food-to-go sales with an irresistible product presentation on eye level. Thanks to the high underframe, the Multi Deck Eyeline provides great visual merchandising. It can be used anywhere in the store to stimulate customers to pick up hot grab-and-go products.

Our patented Hot Blanket holding technology controls food safety. Hot air is blown from the front of the shelf and circulates over the shelf surface, after which it is recycled into the unit. Your products are completely surrounded by a blanket of hot air, ensuring an even holding temperature.

Large, transparent side panels provide a 180-degree view on your products. The appealing design provides an outstanding product presentation which is sure to boost impulse sales.

Features MD 120 - 3 Premium Eycline

Top features

- Eye-level presentation - high underframe
- Illuminated canopy with customizable signage
- Customizable price strips on each shelf
- Hot Blanket holding technology - keeps products warm at 65° for at least 4 hours
- Endless possibilities - ideal for chicken (portions), panini, pies, pastries, soups, hot rolls, wraps etc.

Standard characteristics

- Self serve heated Multi Deck display unit
- Curved design
- 120 cm wide - 3 level display
- Total presentation area of 1.59 m²
- Footprint of 0.96 m²
- Solid back
- Angled shelves provide optimum product visibility
- Shatter-resistant clear side glass for optimum safety
- Front bumpers to protect from shopping carts
- Saves up to 20% on energy by air-curtain technology on each shelf
- 98% recyclable (environmentally friendly)
- Plug-and-play

Accessories

- Customer-side temperature indicator
- Shelf leveler



Optimum product visibility



Signage



High underframe



Keeps hot food at 65°C

MD 120-3 Premium Eyeline

1 Power cable, 2 m

Dimensions

Width	1200 mm
Depth	800 mm
Height	1800 mm

Technical data

Net weight	229 kg
Gross weight	235 kg
Voltage	3N~ 400/230
Frequency	50/60 Hz
Power	3.6 kW

Specifications and technical data are subject to amendment without notice.

These are basic drawings. For more detailed technical information, please refer to the installation manual at www.frijado.com.

