

Project: _____ Location: _____ Item #: _____ Quantity: _____

Short Specification

XLR8[™] Heavy duty upper heated platen for mounting on any AccuSteam[™] 24" cooking depth griddle. XLR8[™] features all stainless-steel construction to maximize strength and longevity. The XLR8[™] utilizes proprietary AccuHeat[™] technology to deliver +/- 10 degree temperature accuracy and near instant recovery of set point temperature. Digital controls feature 3 preset temperatures and a temperature range from 200°- 440°F. XLR8[™] controller also features an automatic built-in timing functionality. The XLR8[™] features 2 different platen float modes built in. Front to back only and gyro, to give the Chef maximum flexibility and control. Robust single hand lift mechanism with top and bottom detent to ensure positive stops. Adjustable gapping and magnetic Teflon hold down handles. Upper platen coverage dimensions 11 ¾" wide x 23 ¾" deep for maximum zone coverage. Mounting bracket required for installation. 208/240V 50/60Hz single phase.

Performance Features

The XLR8[™] proprietary AccuHeat[™] technology ensures maximum performance no matter the application. With its even temperatures and near instant recovery, the XLR8[™] outperforms all the competition with faster cook times, more consistent product quality and improved product safety.

Standard Control Features

- All stainless-steel construction
- AccuHeat[™] technology provides even heat and near instant recovery
- Single hand lift mechanism with positive top and bottom detents to ensure smooth operation and positive stops
- Temperature Range from 200°- 440°F
- 2 different platen float modes
- Automatic built in timing functionality
- Includes 10 non-proprietary Teflon sheets

- Magnetic Teflon hold down handles
- Dual voltage 208/240V 50/60Hz single phase (max 12 amp draw per arm)
- Easy to use gap adjuster
- One Year Parts and Labor Warranty
- Upper platen coverage dimensions are 11 ¾" wide x 23 ¾" deep for maximum zone coverage

Compatibility

XLR8[™] mounts on any natural gas or electric AccuSteam[™] griddle featuring a 24" cooking surface ("B depth"). Mounting Bracket Kit required and sold separately.

- AT2A-6374-1 24" Electric Kit
- AT2A-6374-2 36" Electric Kit
- AT2A-6374-3 48" Electric Kit
- AT2A-6374-4 24" Gas Kit
- AT2A-6374-5 36" Gas Kit
- AT2A-6374-6 48" Gas Kit

Safety, Sanitation & Environmental



Options & Accessories

- Upgrade to automatic timer functionality from factory
- Enable griddle for mounting XLR8[™] arm/ arms from factory
- Mounting Bracket required for installation on 2', 3' or 4' -24" deep cooking surface AccuSteam[™] Griddle. Allows for mounting 1 arm every 12"
- Bezel for Teflon
- Teflon sheet, 10 pack, generic



(2) XLR8 Arms shown mounted on 24" griddle.

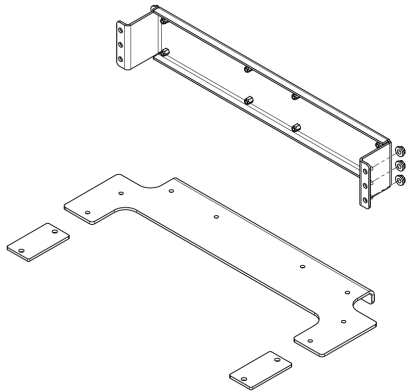

Mounting bracket illustrated and required.
Available in 2', 3' or 4'.

XLR8 Upper Heated Platen (Replace *** with voltage)	
Model #	XLR8***18-00
208/1 Amp/ kW	10 A / 2.1 kW
240/1 Amp / kW	11.3 A / 2.7 kW
Breaker Size	15A
Unit Width (1 arm)	11.50
NEMA Plug (208/240)	L6-30P

Notes:

1. Each XLR8™ Arm comes with 6' power cord, separate receptacle needed for each unit.
2. For use on individual branch circuits only.

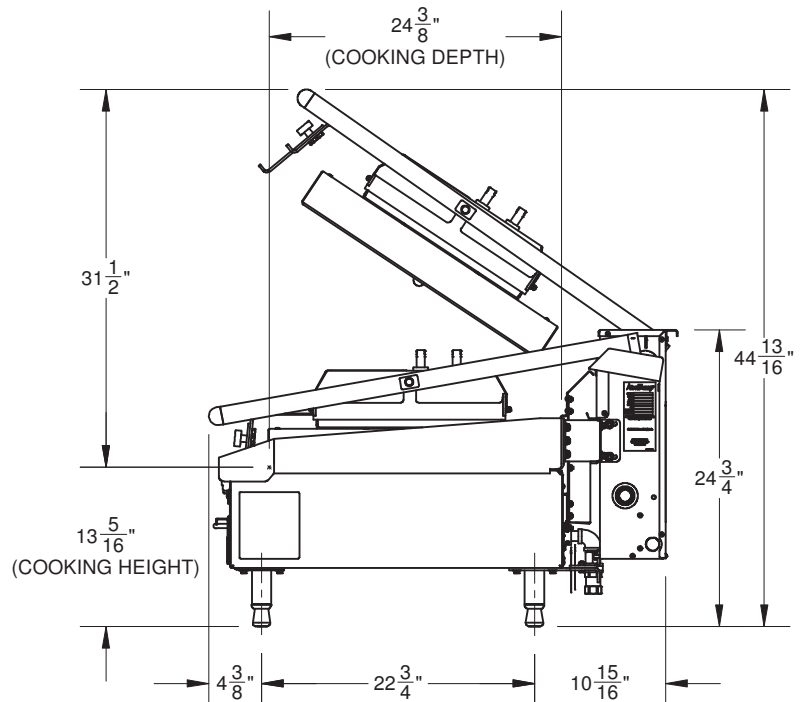
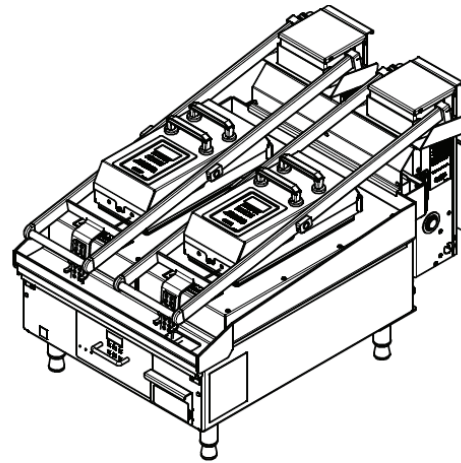
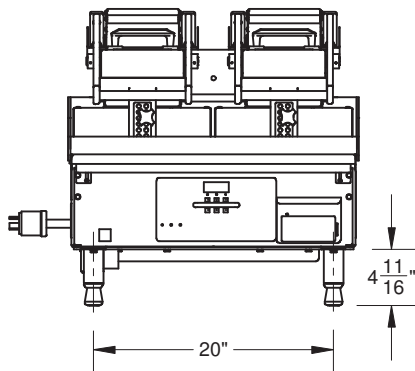
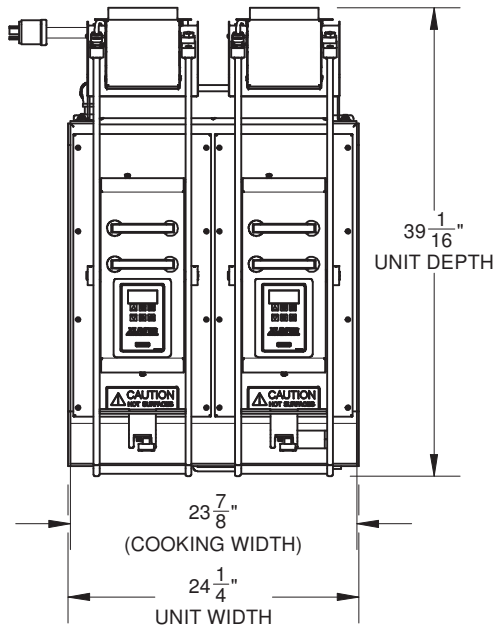

Drawing shown with (2) XLR8 Upper Heated Arms