



### AGBU-2

Shown with 6" casters (optional)  
Hand polished stainless steel finish

#### STANDARD FEATURES

- Stainless steel rugged body.
- 6" deep front stainless steel bullnose landing ledge/work space.
- 6" high polished chrome adjustable steel legs.
- Heavy gauge welded frame construction.
- 24,000 BTU/hr. infrared burners.
- Polished glossy black knobs.
- (2) 6 1/2" adjustable broiler grid at 5 different positions.
- One year limited warranty, parts and labor.

#### OPTIONAL FEATURES

- Stainless steel skewer holder guides.
- Swivel casters in lieu of 6" legs.
- 3/4" x 36" Quick disconnect with restraining device, A53202.
- 3/4" x 48" Quick disconnect with restraining device, A53200.
- 3/4" x 60" Quick disconnect with restraining device, A53201.

The American Range Double Deck Infrared Overfired Broiler has a reputation that lives up to its name. The AGBU-2 gas-fired powerhouse has eight infrared burners that direct nearly 192,000 BTU/hr. of 1850° infrared heat downward to penetrate and sear the exposed surface of the meat, fish, vegetable or casserole products. Since the cooking is accomplished using only infrared heat, the food experiences minimal shrinkage and retains juices, tenderness and flavor.

To help tailor cooking power to the menu, the individual burner gas valves can be used to change the output power of the broiler. The broiler grid is spring-balanced and 4 1/2" adjustable with 5 different positions – so raising and lowering the four position deck is easy. Extending the full width of the broiler, the removable grease tray makes cleanup a snap.

Look to American Range to provide commercial cooking performance, quality and durability - today and whenever you need to upgrade your equipment.

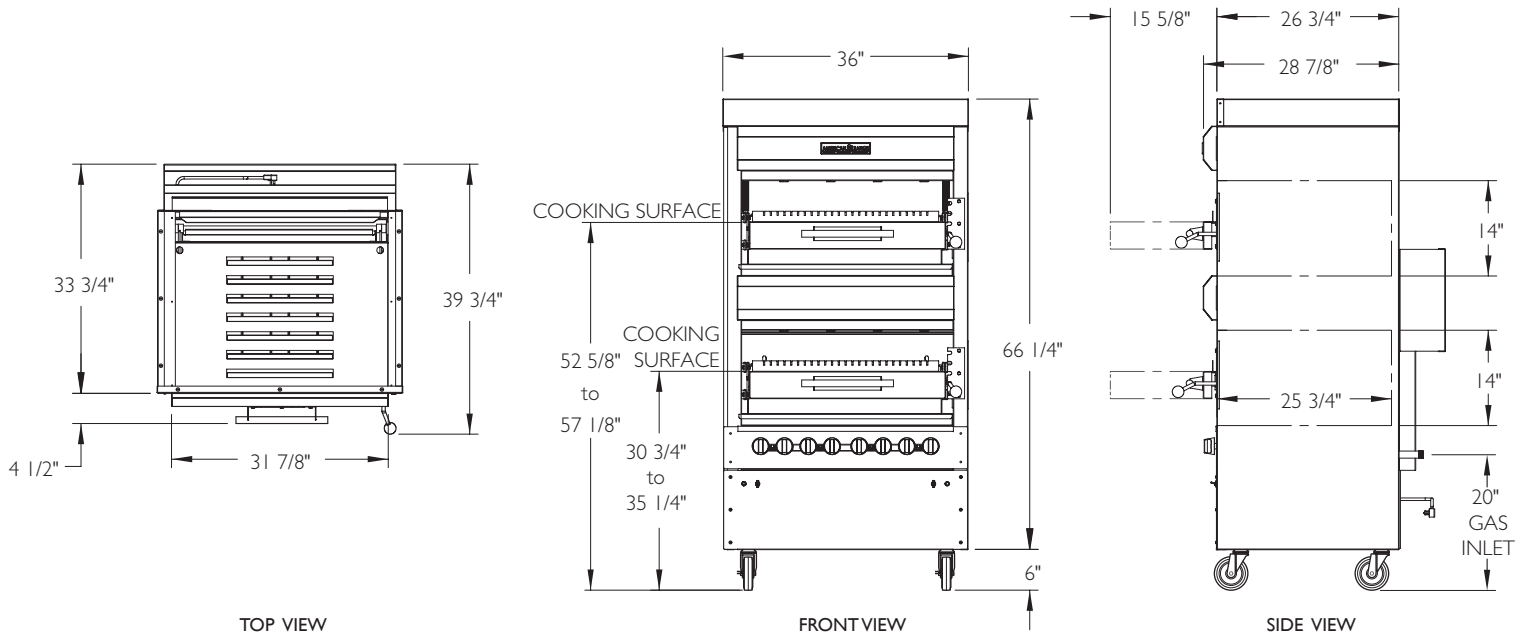

NOT TO SCALE

Model	Width	Depth	Height	Burners	Total BTU	KW	AMPS	Shipping Weight	Lbs.	Kg.
AGBU-2	36"	33-3/4"	66-1/4"	8	192,000	56	1.0		808	367

**STANDARD FEATURES**

- Stainless steel rugged body.
- 6" deep front stainless steel bullnose landing ledge/work space.
- 6" high polished chrome adjustable steel legs.
- Heavy gauge welded frame construction.
- 24,000 BTU/hr. infrared burners, industry's highest.
- Polished glossy black knobs.
- 6', 120V, 3 prong cord.
- (2) 6 1/2" adjustable broiler grid with 5 positions.
- (2) Motors.
- One year limited warranty, parts and labor.

**OPTIONAL FEATURES**

- Stainless steel skewer holder base holder guides.
- 6" Swivel casters.
- 3/4" x 36" Quick disconnect with restraining device, A53202.
- 3/4" x 48" Quick disconnect with restraining device, A53200.
- 3/4" x 60" Quick disconnect with restraining device, A53201.

**GAS SUPPLY:** 3/4" NPT Gas inlet 7" to 9" W.C., Manifold pressure is 5.0" W.C. for natural gas, or 11" - 12" Manifold pressure is 10.0" W.C. for propane gas. Specify type of gas and altitude if over 2000 feet.

**CLEARANCES:** For use only on non-combustible floors. Legs or casters are required, or 2" (51mm) overhang is required when curb mounted. Clearance from non-combustible walls is 0". Non-combustible locations only.

\*NOTE: The American Range Company continually improves its products and reserves the right to change materials, specifications and dimensions without notice. This unit is manufactured for commercial use only.