



ARPR-36

Hand polished stainless steel finish

STANDARD FEATURES

- Stainless Steel front, top and sides. 8" Stainless Steel legs with adjustable feet.
- Equipped with safety pilot, and removable covers over burners, to prevent clogging.
- Full size removable Stainless Steel grease pan.
- Two "U" type burners surround the full depth and rear.
- Thermostatic control provides even heat distribution.
- Fully enclosed 3" thick insulation for energy efficiency. Upper section of roaster has three track levels to hold rods or oven racks.
- Long slabs of ribs, meat or duck may be vertically hung in this large oven.
- Roaster door may be hinged left or right for easy access, right hinge is standard.
- One year limited warranty, parts and labor.



The American Range ARPR Gas Chinese Pork Roaster was designed for continuous rugged use and performance. All the latest technology is incorporated to give you the best value for your money. This roaster features two U-type burners that surround the full depth and rear, and thermostatic controls provide even heat distribution in the cabinet. The ARPR Chinese Pork Roaster features a durable stainless steel front, top, sides, and 8" inch legs with adjustable feet.

SCALE: NOT TO SCALE

CHINESE PORK ROASTERS

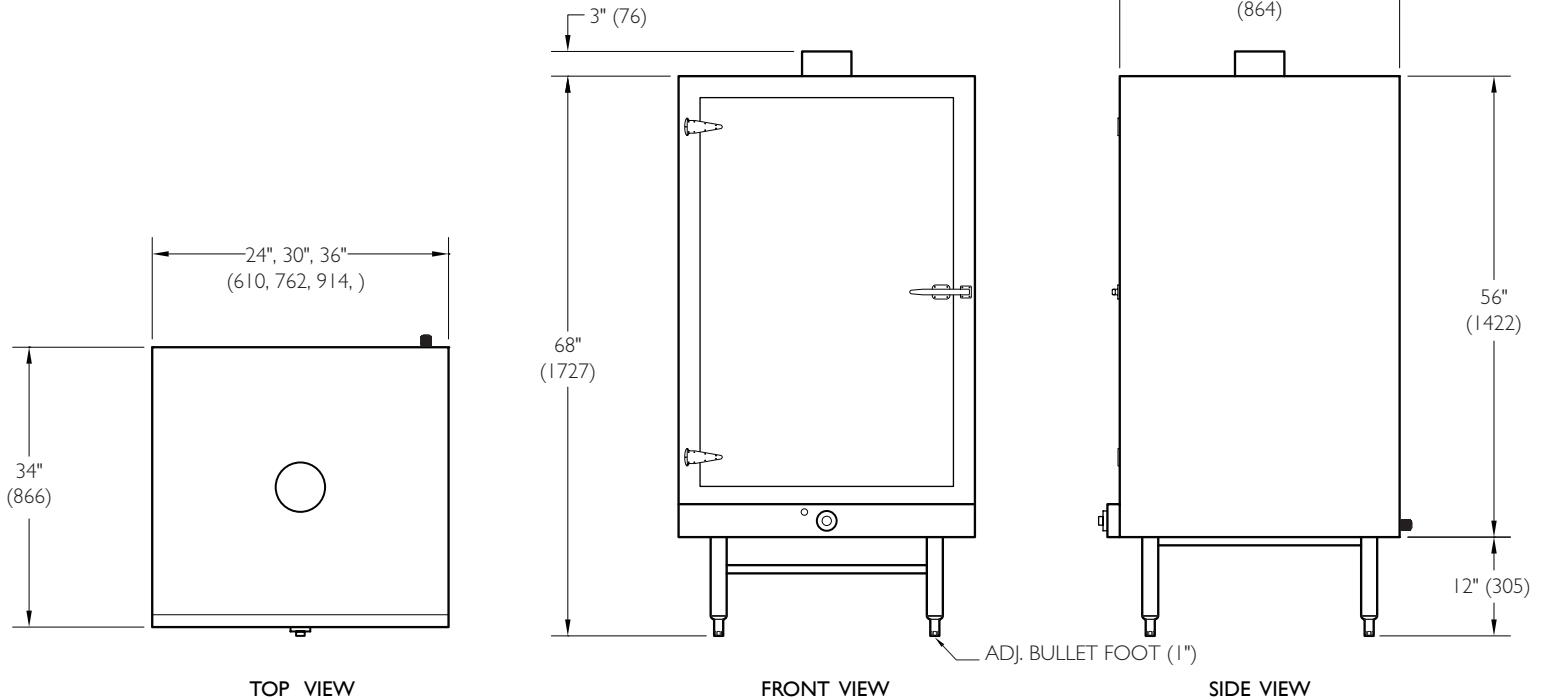

Model	Width	Depth	Height	Burners	Total BTU	KW	Shipping Weight	Lbs.	Kg.
ARPR-24	24"(610)	34"(864)	68"(1727)	2	50,000	(15)	450	(203)	
ARPR-30	30"(762)	34"(864)	68"(1727)	2	55,000	(16)	550	(249)	
ARPR-36	36"(914)	34"(864)	68"(1727)	4	60,000	(18)	675	(305)	

STANDARD FEATURES

- Stainless Steel front, top and sides. 8" Stainless Steel legs with adjustable feet.
- Equipped with safety pilot, and removable covers over burners, to prevent clogging.
- Full size removable Stainless Steel grease pan.
- Two "U" type burners surround the full depth and rear.
- Thermostatic control provides even heat distribution.
- Fully enclosed 3" thick insulation for energy efficiency. Upper section of roaster has three track levels to hold rods or oven racks.
- Long slabs of ribs, meat or duck may be vertically hung in this large oven.
- Roaster door may be hinged left or right for easy access; right hinge is standard.
- One year limited warranty, parts and labor.

OPTIONAL FEATURES

- Stainless Steel "S" hooks.
- Pork roaster skewers.
- Pork roaster oven racks.

CLEARANCES: For use only on non-combustible floors. Legs or casters are required, or 2" (51) overhang is required when curb mounted. Clearance from non-combustible walls is 0". When unit is placed next to combustible walls, clearances must exceed 12" (305) on sides, and 4" (102) from rear. Radiant broilers for non-combustible locations only.

GAS SUPPLY: 3/4" NPT Gas inlet 7" to 9" W.C., Manifold pressure is 5.0" W.C. for natural gas, or 11" - 12" Manifold pressure is 10.0" W.C. for propane gas. Specify type of gas and altitude if over 2000 feet.

*The American Range Company continually improves its products and reserves the right to change materials, specifications and dimensions without notice. This unit is manufactured for commercial use only.