

# Mouth-watering display

Hot Deli 3



The Hot Deli curved merchandisers are available in 3, 4 and 5 pan sizes. It can be built-in into existing counters or installed on a matching floor-mounted stand. The Hot Deli can also be combined with the Cold Deli to display both your hot and cold food products in one matching design.

The Hot Deli Essential and Self-Serve are based on simplicity. All basic features are united in these cabinets without quality and finishing being compromised. These counters contain the perfect holding conditions to keep your products fresh.

The Hot Deli Premium is complete in functionality. It features independent upper radiant heat to control humidity over each GN-section. In order to ensure ideal holding conditions, humidification can be set at four different levels. The mild airflow enables you to hold and display the most versatile food products with different holding requirements.

## Features Hot Deli 3 curved

### Top features

- Curved glass
- Product temperature maintained at 65°C
- Mirror-effect sliding doors on operator side
- Hot and cold, full serve and self serve can be combined in one design

### Standard characteristics

- Presentation area width of 3 GN-pans
- Available in Premium, Essential and self serve
- Plug and play
- Optional underframe

### Premium full serve

- 4-step humidified operation with built-in low water alarm
- Independently controlled upper radiant heat per section
- Pan frame for 3x1/1 GN-pan plus 3x1/3 GNpan per section

### Essential full serve

- Simple controls
- Pan frame for 3x1/1 GN-pan plus 3x1/3 GN-pan per section

### Self serve

- Simple controls
- Flat plate: 964 mm x 608 mm



Hot Deli 3 Curved Full-Serve



Hot Deli Square



Control panel Premium



Second level

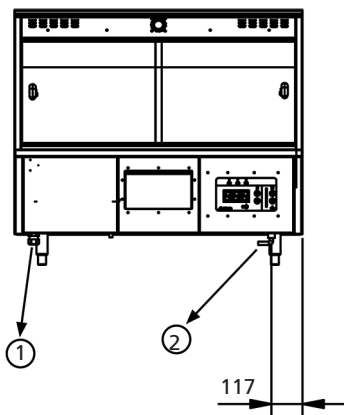
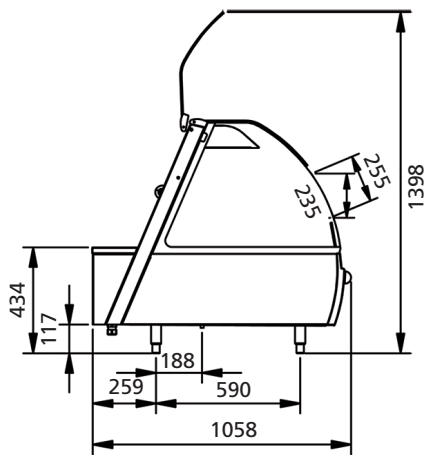
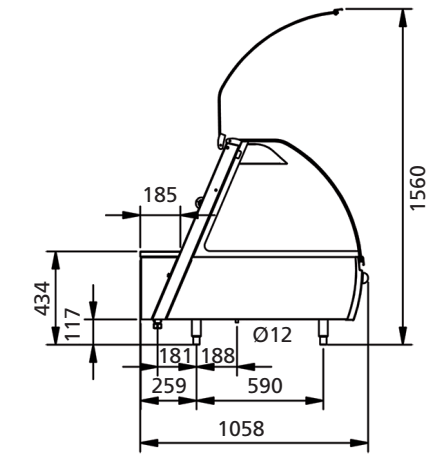

	HD Premium	HD Essential	HD Self-Serve
Full serve operation	■	■	
Self serve operation			■
Available in curved glass or square glass	■	■	■
Mirrored sliding rear doors	■	■	■
Three-button control panel		■	■
Digital control panel	■		
4-step humidity	■		
Built-in low water alarm	■		
Radiant heat	■	■	■
Independently controlled radiant heat per GN section	■		
Front glass lifts on gas springs	■	■	
Panframe standard	■	■	optional
Flat plate standard	optional	optional	■
Cutting board	optional	optional	optional
Automatic water filling system	optional		
Second level display rack	optional	optional	optional
Temperature indicator	optional	optional	optional

	HD 3 Premium	HD 3 Essential	HD 3 Self-Serve
Width	1086 mm	1086 mm	1086 mm
Depth	1058 mm	1058 mm	1058 mm
Height	960 mm	960 mm	960 mm
Height on stand	1420 mm	1420 mm	1420 mm
Height on low stand	1300 mm	1300 mm	1300 mm
Net weight	153 kg	139 kg	134 kg
Gross weight	185 kg	166 kg	160 kg
Voltage	3N~ 400/230 V	3N~ 400/230 V	3N~ 400/230 V
Frequency	50/60 Hz	50/60 Hz	50/60 Hz
Power	4.6 kW	3.7 kW	3.7 kW

## Hot Deli 3 Curved

- 1 Power cable 2.5 m
- 2 Hose pillar (automatic water-filling only)

Specifications and technical data are subject to amendment without notice.

These are basic drawings. For more detailed technical information, please refer to the installation manual at [www.frijado.com](http://www.frijado.com).

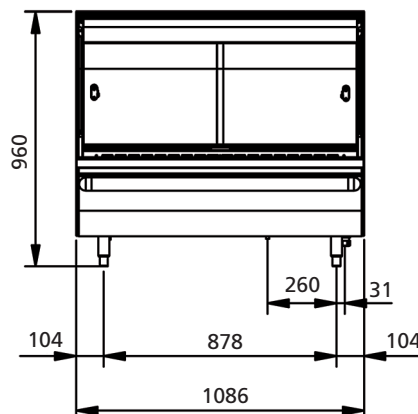

# Mouth-watering display

Hot Deli 4



The Hot Deli curved merchandisers are available in 3, 4 and 5 pan sizes. It can be built-in into existing counters or installed on a matching floor-mounted stand. The Hot Deli can also be combined with the Cold Deli to display both your hot and cold food products in one matching design.

The Hot Deli Essential and Self-Serve are based on simplicity. All basic features are united in these cabinets without quality and finishing being compromised. These counters contain the perfect holding conditions to keep your products fresh.

The Hot Deli Premium is complete in functionality. It features independent upper radiant heat to control humidity over each GN-section. In order to ensure ideal holding conditions, humidification can be set at four different levels. The mild airflow enables you to hold and display the most versatile food products with different holding requirements.

## Features Hot Deli 4 curved

### Top features

- Curved glass
- Product temperature maintained at 65°C
- Mirror-effect sliding doors on operator side
- Hot and cold, full serve and self serve can be combined in one design

### Standard characteristics

- Presentation area width of 4 GN-pans
- Available in Premium, Essential and self serve
- Plug and play
- Optional underframe

### Premium full serve

- 4-step humidified operation with built-in low water alarm
- Independently controlled upper radiant heat per section
- Pan frame for 4x1/1 GN-pan plus 4x1/3 GN-pan per section

### Essential full serve

- Simple controls
- Pan frame for 4x1/1 GN-pan plus 4x1/3 GN-pan per section

### Self serve

- Simple controls
- Flat plate: 1297 mm x 608 mm



Hot Deli 4 Curved Full-Serve



Hot Deli Square

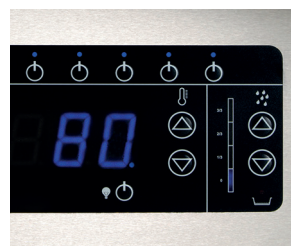

Control panel Premium



Second level

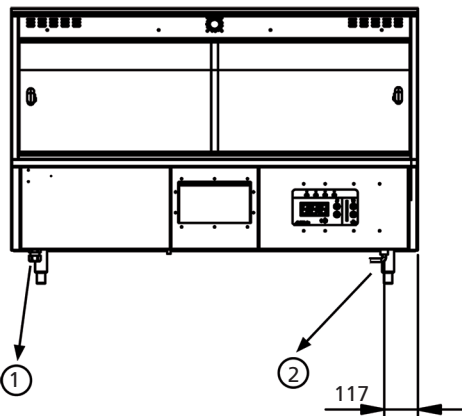
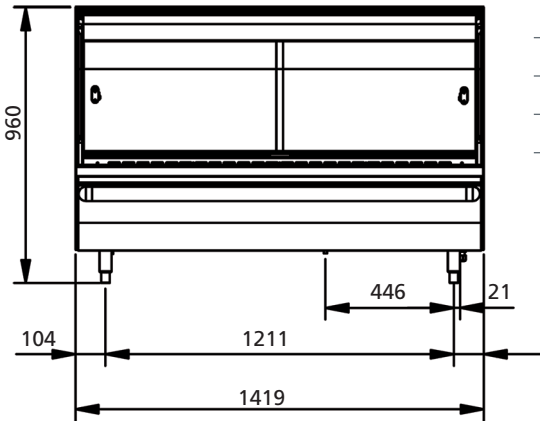
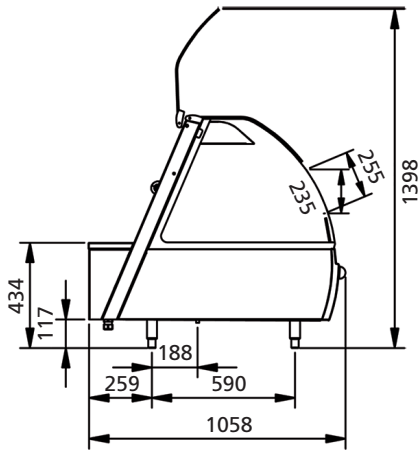
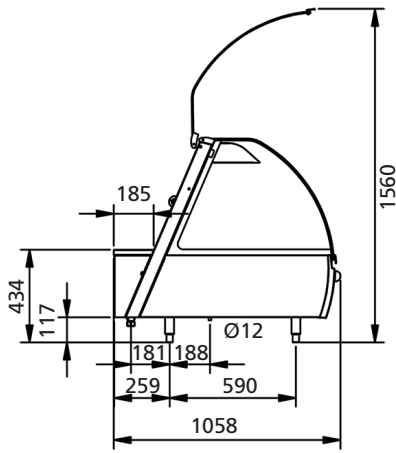

	HD Premium	HD Essential	HD Self-Serve
Full serve operation	■	■	
Self serve operation			■
Available in curved glass or square glass	■	■	■
Mirrored sliding rear doors	■	■	■
Three-button control panel		■	■
Digital control panel	■		
4-step humidity	■		
Built-in low water alarm	■		
Radiant heat	■	■	■
Independently controlled radiant heat per GN section	■		
Front glass lifts on gas springs	■	■	
Panframe standard	■	■	optional
Flat plate standard	optional	optional	■
Cutting board	optional	optional	optional
Automatic water filling system	optional		
Second level display rack	optional	optional	optional
Temperature indicator	optional	optional	optional

	HD 4 Premium	HD 4 Essential	HD 4 Self-Serve
Width	1419 mm	1419 mm	1419 mm
Depth	1058 mm	1058 mm	1058 mm
Height	960 mm	960 mm	960 mm
Height on stand	1420 mm	1420 mm	1420 mm
Height on low stand	1300 mm	1300 mm	1300 mm
Net weight	175 kg	161 kg	151 kg
Gross weight	247 kg	221 kg	221 kg
Voltage	3N~ 400/230 V	3N~ 400/230 V	3N~ 400/230 V
Frequency	50/60 Hz	50/60 Hz	50/60 Hz
Power	4.9 kW	4 kW	4 kW

## Hot Deli 4 Curved

- 1 Power cable 2.5 m
- 2 Hose pillar (automatic water-filling only)

Specifications and technical data are subject to amendment without notice.

These are basic drawings. For more detailed technical information, please refer to the installation manual at [www.frijado.com](http://www.frijado.com).

# Mouth-watering display

Hot Deli 5



The Hot Deli curved merchandisers are available in 3, 4 and 5 pan sizes. It can be built-in into existing counters or installed on a matching floor-mounted stand. The Hot Deli can also be combined with the Cold Deli to display both your hot and cold food products in one matching design.

The Hot Deli Essential and Self-Serve are based on simplicity. All basic features are united in these cabinets without quality and finishing being compromised. These counters contain the perfect holding conditions to keep your products fresh.

The Hot Deli Premium is complete in functionality. It features independent upper radiant heat to control humidity over each GN-section. In order to ensure ideal holding conditions, humidification can be set at four different levels. The mild airflow enables you to hold and display the most versatile food products with different holding requirements.

## Features Hot Deli 5 curved

### Top features

- Curved glass
- Product temperature maintained at 65°C
- Mirror-effect sliding doors on operator side
- Hot and cold, full serve and self serve can be combined in one design

### Standard characteristics

- Presentation area width of 5 GN-pans
- Available in Premium, Essential and self serve
- Plug and play
- Optional underframe

### Premium full serve

- 4-step humidified operation with built-in low water alarm
- Independently controlled upper radiant heat per section
- Pan frame for 5x1/1 GN-pan plus 5x1/3 GN-pan per section

### Essential full serve

- Simple controls
- Pan frame for 5x1/1 GN-pan plus 5x1/3 GN-pan per section

### Self serve

- Simple controls
- Flat plate: 1630 mm x 608 mm



Hot Deli 5 Curved Full-Serve



Hot Deli Square



Control panel Premium



Second level

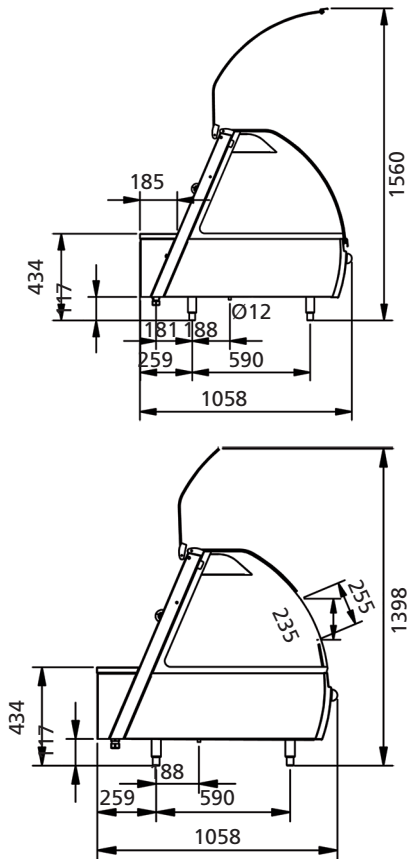

	HD Premium	HD Essential	HD Self-Serve
Full serve operation	■	■	
Self serve operation			■
Available in curved glass or square glass	■	■	■
Mirrored sliding rear doors	■	■	■
Three-button control panel		■	■
Digital control panel	■		
4-step humidity	■		
Built-in low water alarm	■		
Radiant heat	■	■	■
Independently controlled radiant heat per GN section	■		
Front glass lifts on gas springs	■	■	
Panframe standard	■	■	optional
Flat plate standard	optional	optional	■
Cutting board	optional	optional	optional
Automatic water filling system	optional		
Second level display rack	optional	optional	optional
Temperature indicator	optional	optional	optional

	HD 5 Premium	HD 5 Essential	HD 5 Self-Serve
Width	1752 mm	1752 mm	1752 mm
Depth	1058 mm	1058 mm	1058 mm
Height	960 mm	960 mm	960 mm
Height on stand	1420 mm	1420 mm	1420 mm
Height on low stand	1300 mm	1300 mm	1300 mm
Net weight	187 kg	173 kg	158 kg
Gross weight	282 kg	255 kg	255 kg
Voltage	3N~ 400/230 V	3N~ 400/230 V	3N~ 400/230 V
Frequency	50/60 Hz	50/60 Hz	50/60 Hz
Power	5.1 kW	4.2 kW	4.2 kW

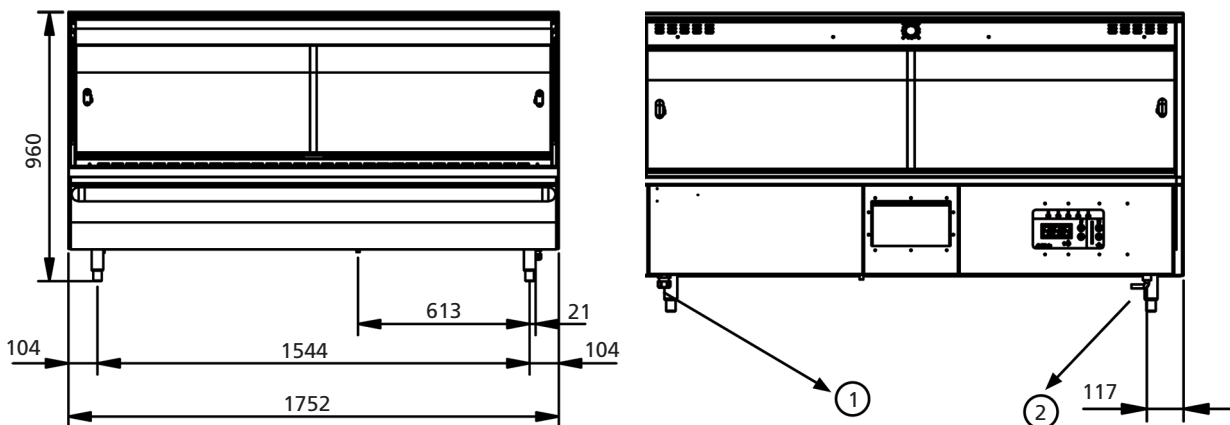

## Hot Deli 5 Curved

- 1 Power cable 2.5 m
- 2 Hose pillar (automatic water-filling only)

Specifications and technical data are subject to amendment without notice.

These are basic drawings. For more detailed technical information, please refer to the installation manual at [www.frijado.com](http://www.frijado.com).