

MODEL NO: GBS FX202E3



MODEL GBS FX202E3 SHOWN



**Capacity:**  
20 2 / 1 pans  
40 1 / 1 pans



### Oven Highlights:

- Multi-function combination oven with digital controls, LED display
- **BOILERLESS TECHNOLOGY** saves energy with no reduction in volume, saves servicing thru reduction of duplicity
- Built to save money and energy through the use of patented new technology
  - **ECO** function - reduces water consumption during the cooking and washing processes.
  - **APM** power management increases power supplied until the desired temperature in the cooking environment is reached
  - **AOC** (patent pending) allows operation with "overpressure cooking environment"
  - **AWC** automatic control of the motor's rotation constantly assuring consistency of cook and colouring
  - The **RDC** (patent pending) steam generator ensures a constant supply of steam throughout "steam" and "combination cooking" modes
- Instantaneous steam generation within oven cavity
- Electronic self-diagnosis with malfunction alarms for key operating areas
- Semi automatic or fully automatic self cleaning ability
- High temperature steam (from overpressure) for Hi-Temp steaming
- Unlimited language selection in Level 3 configuration
- Thumb drive (USB) software management (lv13)

### STRUCTURAL FEATURES - ALL MODELS

- Frame On construction using 20 gauge #304 Stainless Steel on ALL exterior components; #316 polished SS in oven interior.
- heat exchangers constructed of ICOLLOY 800 and #316 Stainless Steel
- Water protection rating of IPX5
- Instantaneous steam generation within oven cavity
- Multiple point height adjustable feet

### SAFETY FEATURES - ALL MODELS

- Autoreverse fan with Automatic oven cooldown
- Automatic cool of cooking chamber when door closed
- Control panel protected by 5mm of tempered glass
- Gently coved interior corners, airtight cooking chamber with a tempered double-glazed opening window,
- Door with intermediate position block - 90° and 130°

### OPERATING FEATURES—ALL MODELS

- Tamper proof cooking program protection
- Cooking chamber with siphoned drain to prevent backflow of liquids and smells
- Automatic pre-heat function
- Easy to operate electronic controls with digital readout
- APM power boost in both gas and electric configurations
- Metric (C) or imperial (F) measure
- Twenty cooking programs, three steps each - modifiable
- Manual steam injection during dry heat cooking

### Cooking Modes:

**Steam** - Moist Heat 86° - 257° F (30° - 125°C)

**Combination** - Dry + Moist Heat 86° - 482° F (30° - 250°C); 0 to 90% Humidity

**Convection** - Dry Heat 86° - 572° F (30° - 300°C)

### LEVEL TWO FEATURES

- 20 four step cooking programs
- Semi automatic, non touch, self cleaning
- Two speed fan, full and half static
- Single point temperature probe
- HACCP print-out interface
- Quick cool down
- 24 hour delayed start option
- Auto "regeneration" quick select button



### LEVEL THREE FEATURES - PARTIAL LIST

- 150 cooking programs that can be customized through 18 phases
- **EVC** touch sensitive multi-function controller with 256,000 colours and up to 70 degree visuals
- **CMP** - custom management page with full digital image control (upload your pictures), video library page, recipe recall feature, delayed cooking clock
- **C3** cooking; select, load and go
- Fully automatic AND touchless sanitizing and washing system with eight cleaning options
- USB drive for HACCP data, menu updating, video uploads, picture/plating uploads and software updates
- **MULTICOOKING** for up to 20 similar profile products, separate timing by shelf position
- **MULTIEASY** allows for the simultaneous cooking of similar type products researched from your cooking library
- Self reversing six speed fan with static setting
- Multi-point core probe with progressive density sensors



MODEL NO: GBS FX202E3

**GBS**  
**COMBISTAR** FX

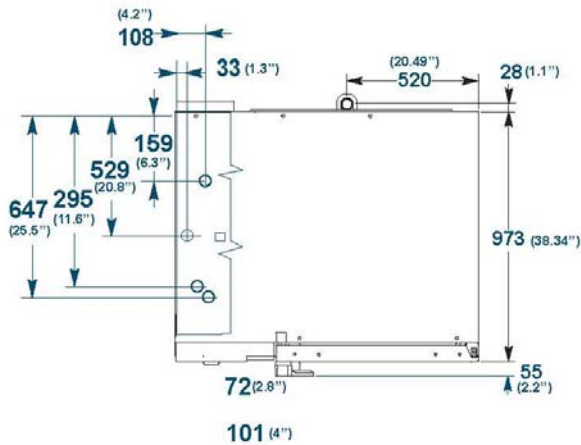
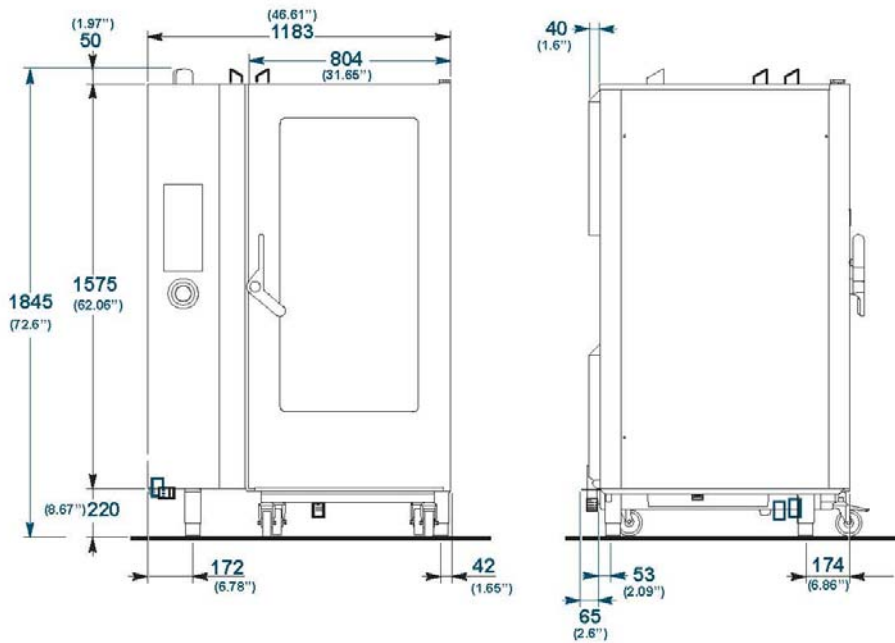

<b>Oven Dimensions / Dimensions du four:</b>	1183 x 973 x 1845 (mm)	46.6 x 38.3 x 72.63 (in.)
<b>Cooking Chamber Dimensions / Dimensions de la chambre:</b>	890 x 825 x 1460 (mm)	35 x 32.5 x 57.5 (in.)
<b>Crated Dimensions / Dimensions d'emballage:</b>	1305 x 1200 x 2173 (mm)	51.38 x 47.25 x 85.57 (in.)
<b>Electrical Supply / Alimentation électrique:</b>	208 V, 2640 W, 144.5 A, 60 Hz, 3 ph	
<b>Weight Net / Poids net:</b>	429 Kg	945 lb
<b>Crated Weight / Poids brut:</b>	449 Kg	989 lb
<b>Capacity / Capacité:</b>	G/N containers: 20 2/1; 40 1/1	



2871 BRIGHTON ROAD.  
OAKVILLE, ONT • L6H 6C9  
T: 905-829-5534 F: 905-829-9914  
[www.qbscooks.com](http://www.qbscooks.com)